

RESISTIVE CONNECTIONS with OEM radio present
 (SEEN FROM CABLE OUPUT OF CONNECTORS) UNIKA rev 2.2.08

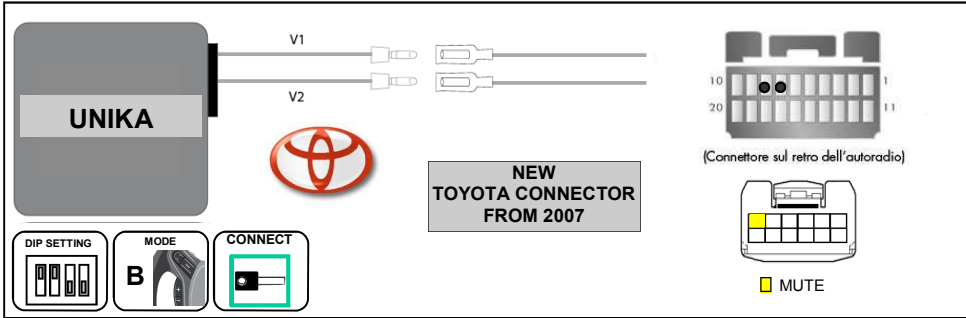

31

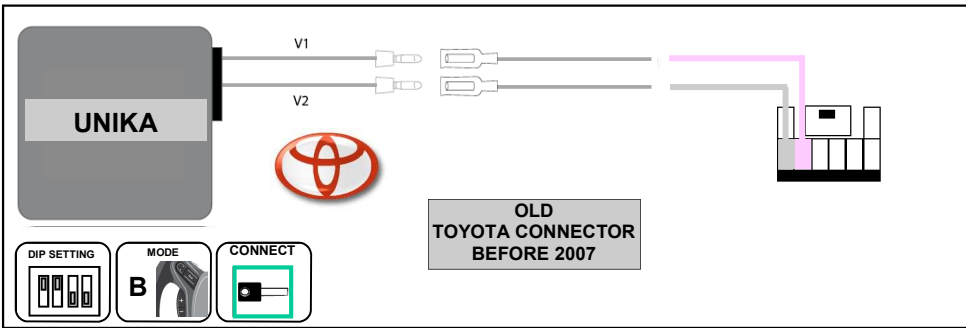

45

CANBUS CONNECTIONS
 (SEEN FROM CABLE OUPUT OF CONNECTORS) UNIKA rev 2.2.08

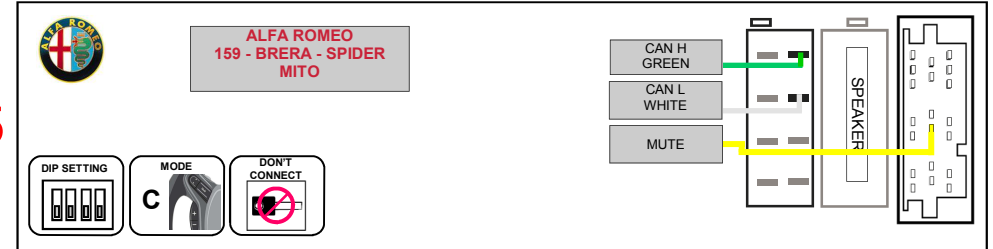

5

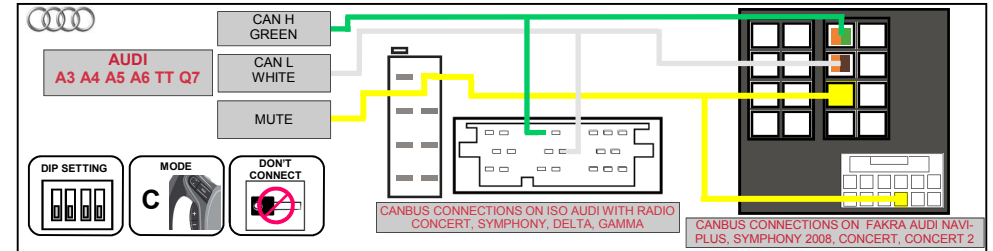

1

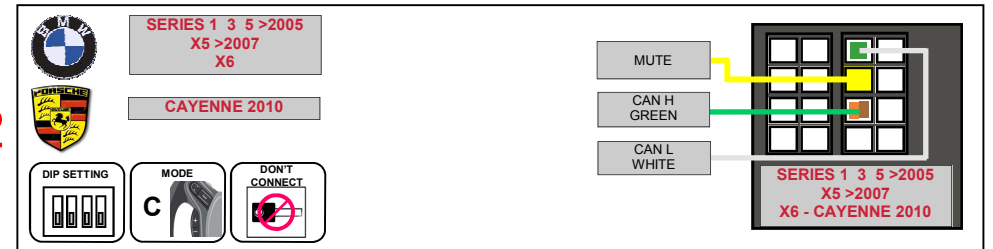

2

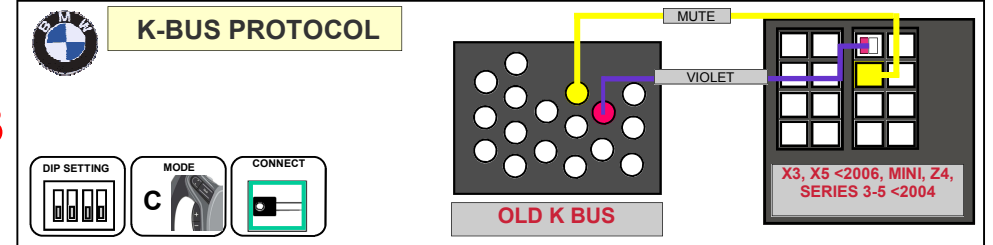

3

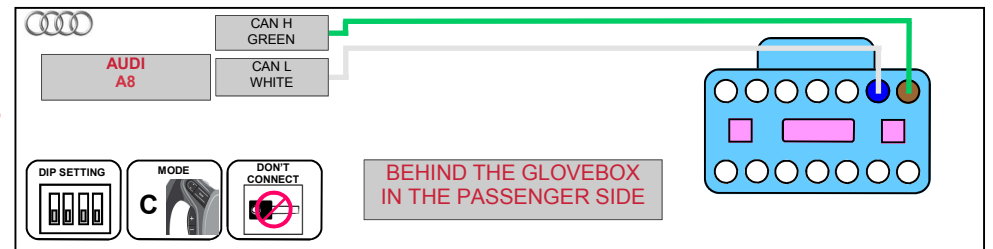

97

CANBUS CONNECTIONS
(SEEN FROM CABLE OUPUT OF CONNECTORS) UNIKA rev 2.2.08

CHRYSLER

CH WHITE/ORANGE
CL WHITE

DIP SETTING: [Diagram of DIP switch]

MODE: A [Diagram of Mode A]

DON'T CONNECT: [Diagram with red X]

**J. GRAND CHEROKEE
COMPASS 300 C
GRAN VOYAGER**

**FAKRA
C2 - C3 - C4 - C5
C4 PICASSO
207 - 307 - 407 - 308 -
3008 - FIAT SCUDO /
JUMPY**

DIP SETTING: [Diagram of DIP switch]

MODE: B [Diagram of Mode B]

DON'T CONNECT: [Diagram with red X]

Dodge

NITRO - CALIBER - JOURNEY

CL WHITE/ORANGE (POS 2)
CH WHITE/GREY (POS 13)

DIP SETTING: [Diagram of DIP switch]

MODE: B [Diagram of Mode B]

DON'T CONNECT: [Diagram with red X]

FIAT

**GRANDE PUNTO
IDEA - STILO - BRAVO - 500
CROMA**

**YPSILON
DELTA**

DIP SETTING: [Diagram of DIP switch]

MODE: B [Diagram of Mode B]

DON'T CONNECT: [Diagram with red X]

Ford

FIESTA 2009

DIP SETTING: [Diagram of DIP switch]

MODE: A [Diagram of Mode A]

DON'T CONNECT: [Diagram with red X]

RESISTIVE CONNECTIONS with OEM radio present
(SEEN FROM CABLE OUPUT OF CONNECTORS) UNIKA rev 2.2.08

UNIKA

V1
V2

SSANGYONG

REXTON - KYRON
ACTYON - KORANDO

massa

DIP SETTING: [Diagram of DIP switch]

MODE: B [Diagram of Mode B]

CONNECT: [Diagram with green box]

UNIKA

V1
V2

SUBARU

FORESTER

massa

DIP SETTING: [Diagram of DIP switch]

MODE: B [Diagram of Mode B]

CONNECT: [Diagram with green box]

UNIKA

V1
V2

SUBARU

IMPREZA >2008
OUTBACK
LEGACY

massa

DIP SETTING: [Diagram of DIP switch]

MODE: B [Diagram of Mode B]

CONNECT: [Diagram with green box]

UNIKA

V1
V2

SUZUKI

GRAND VITARA
VITARA
SWIFT

Massa

BACK THE RADIO

MUTE

DIP SETTING: [Diagram of DIP switch]

MODE: B [Diagram of Mode B]

CONNECT: [Diagram with green box]

RESISTIVE CONNECTIONS with OEM radio present
 (SEEN FROM CABLE OUPUT OF CONNECTORS) UNIKA rev 2.2.08

40

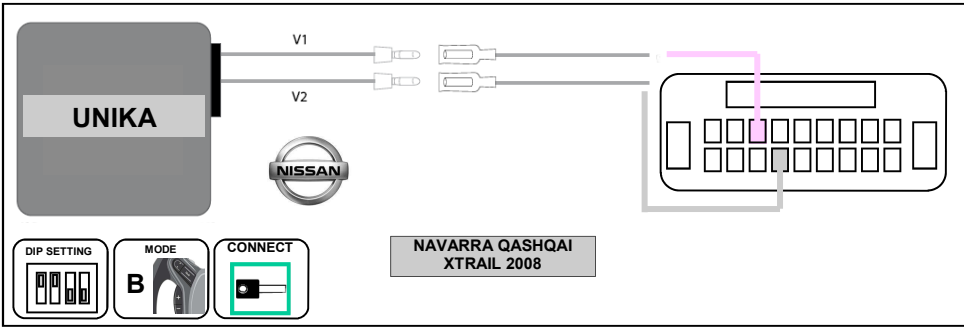

41

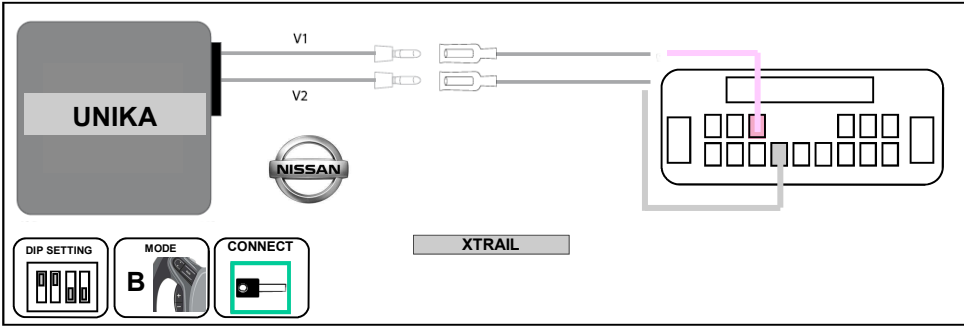

42

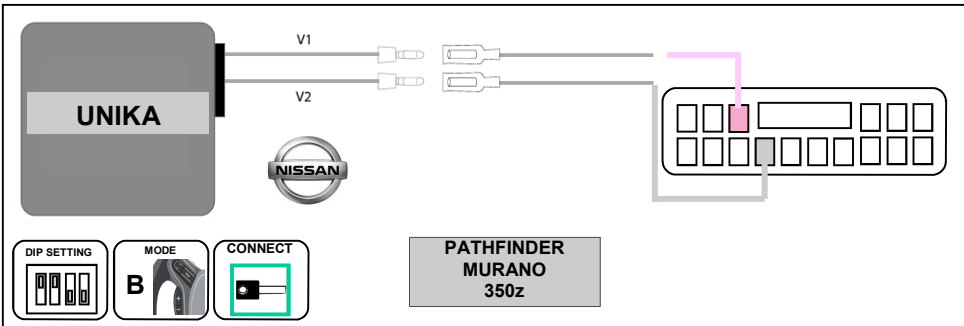

29

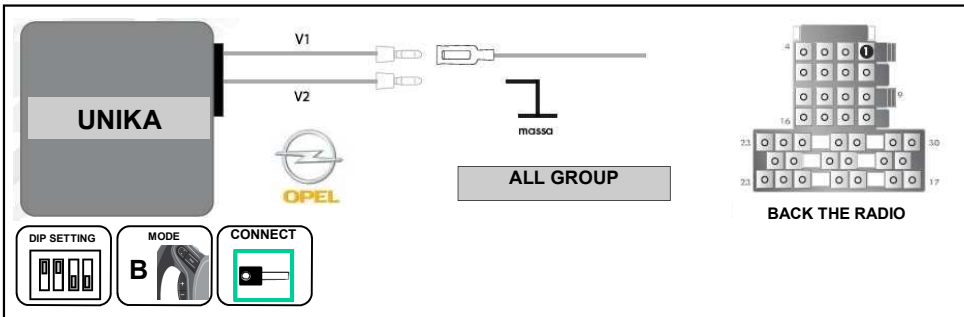

CANBUS CONNECTIONS
 (SEEN FROM CABLE OUPUT OF CONNECTORS) UNIKA rev 2.2.08

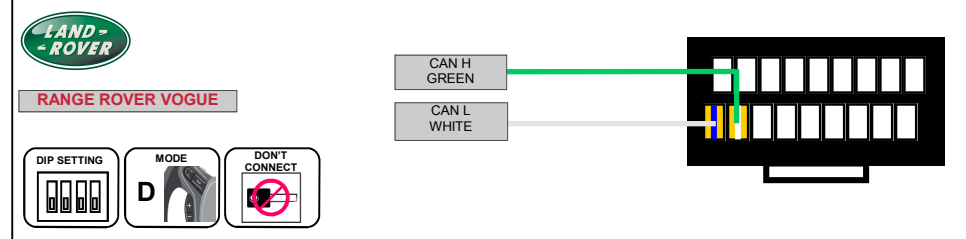

92

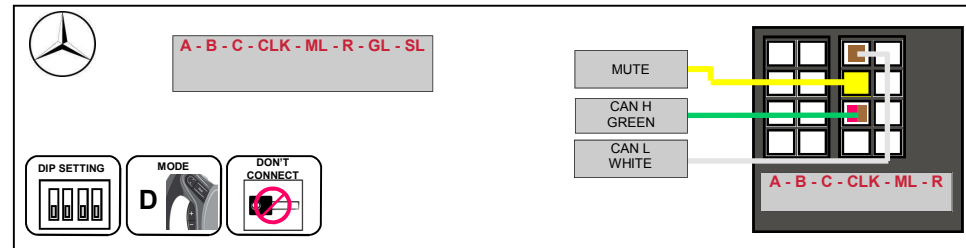

8

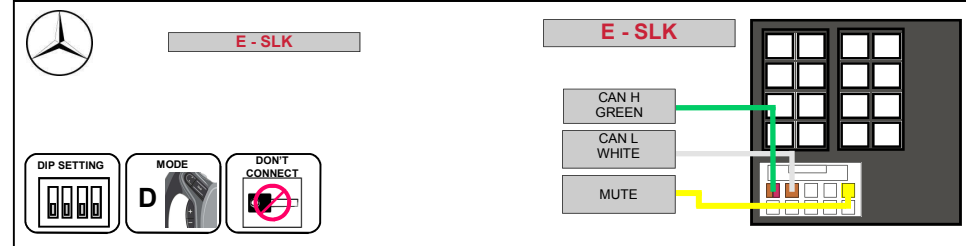

9

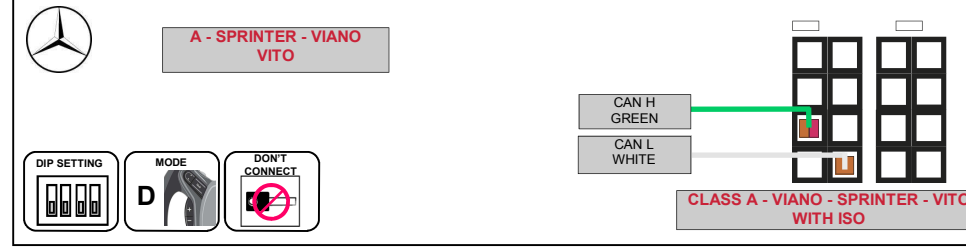

10

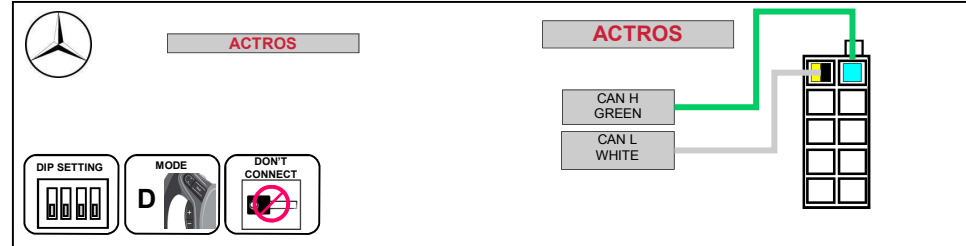

88

CANBUS CONNECTIONS
(SEEN FROM CABLE OUPUT OF CONNECTORS) UNIKA rev 2.2.08

87

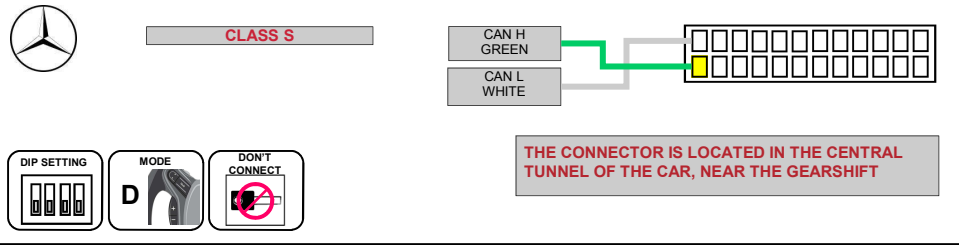

15

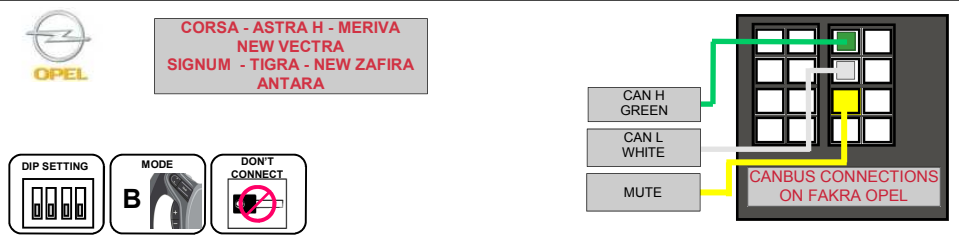

18

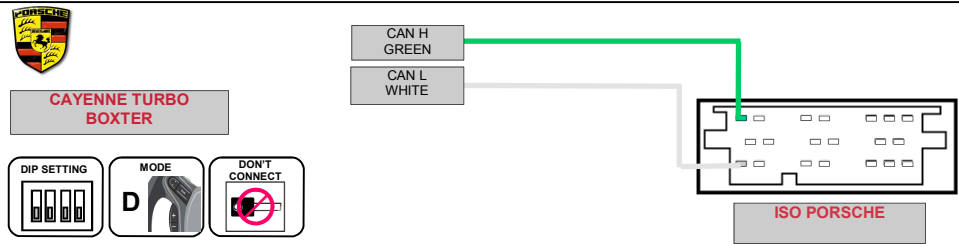

11

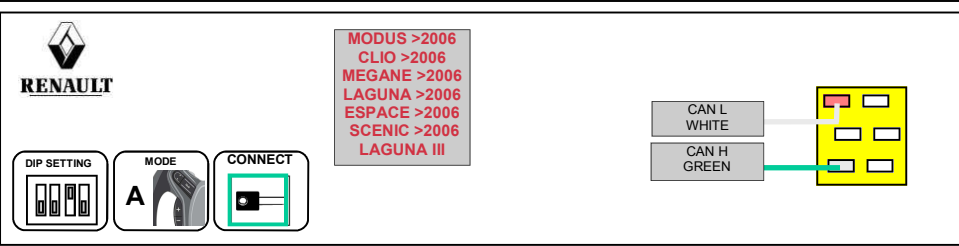

89

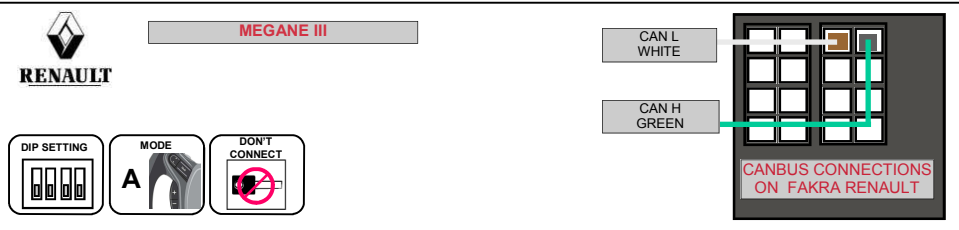

RESISTIVE CONNECTIONS with OEM radio present
(SEEN FROM CABLE OUPUT OF CONNECTORS) UNIKA rev 2.2.08

96

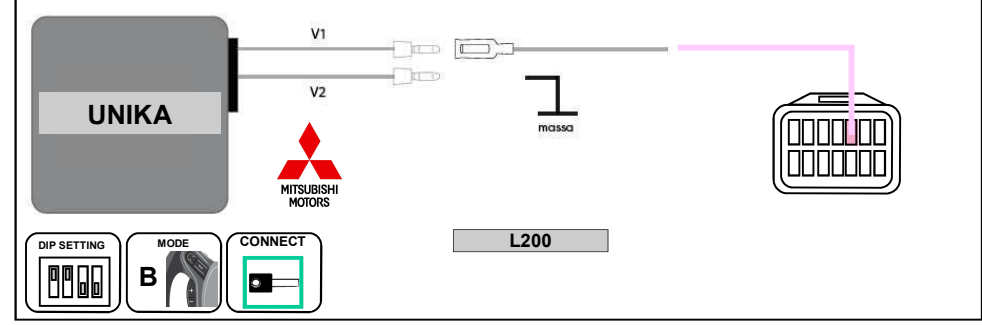

34

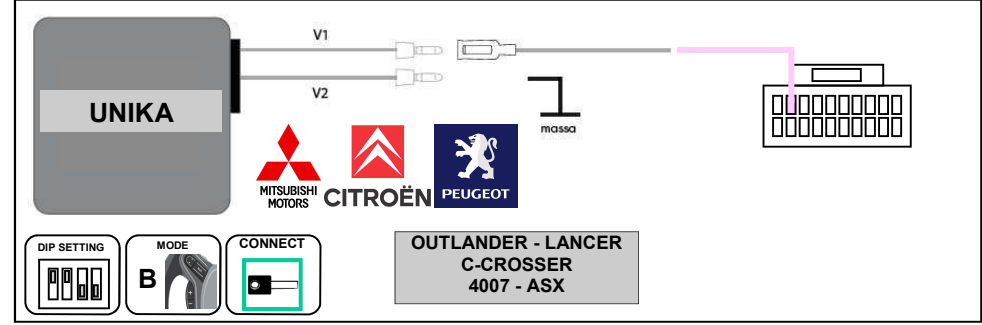

38

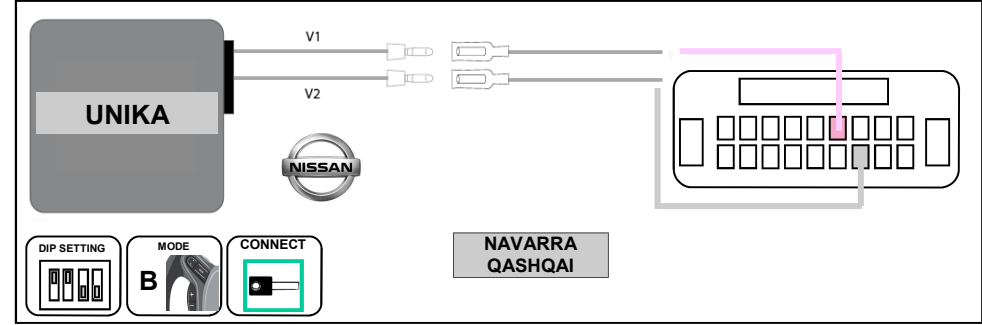

28

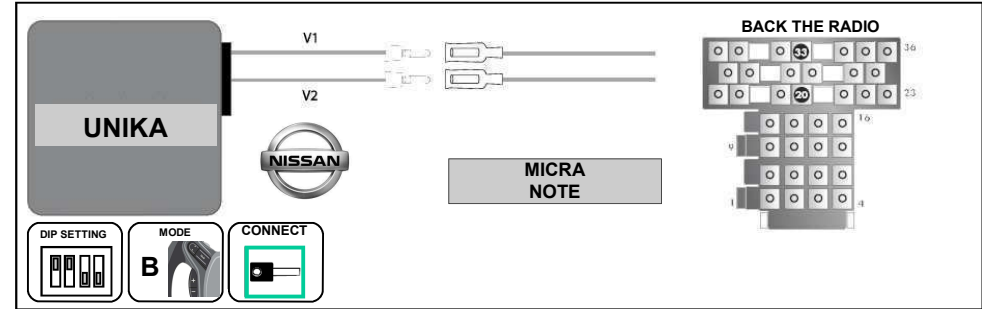

RESISTIVE CONNECTIONS with OEM radio present
 (SEEN FROM CABLE OUPUT OF CONNECTORS) UNIKA rev 2.2.08

44

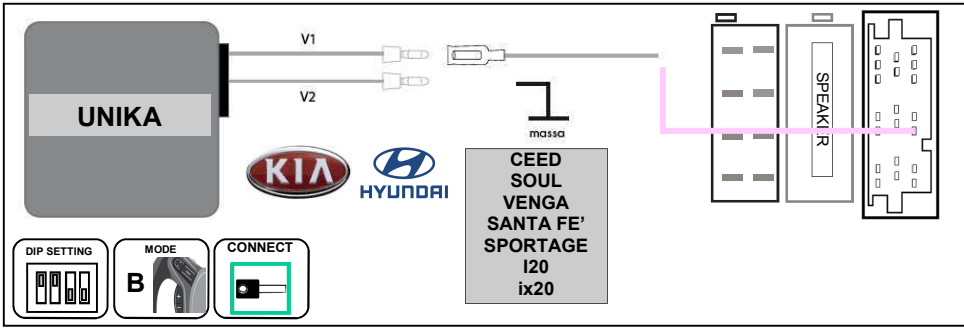

37

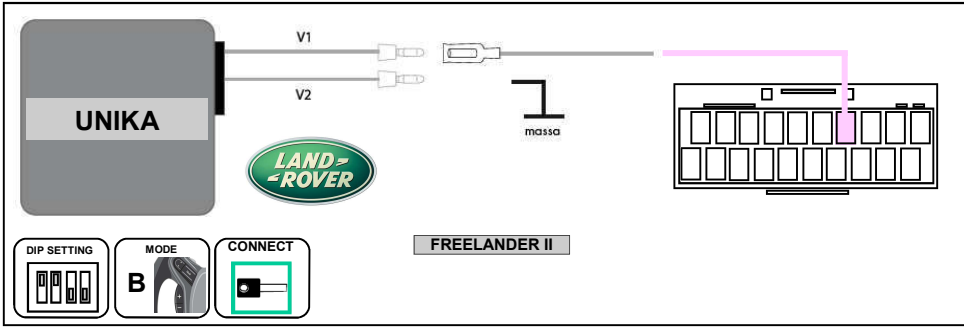

26

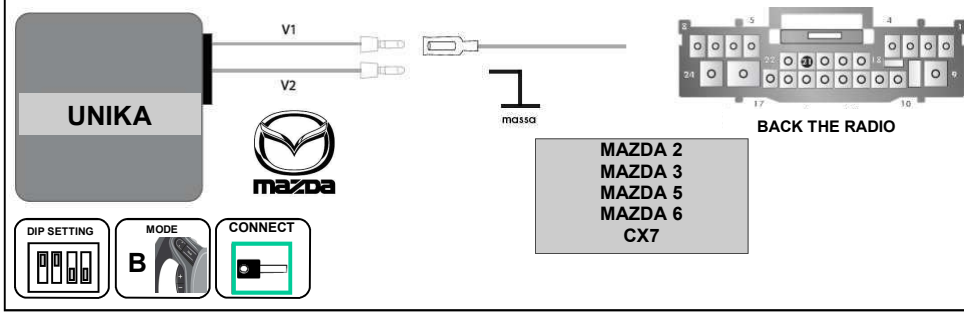

36

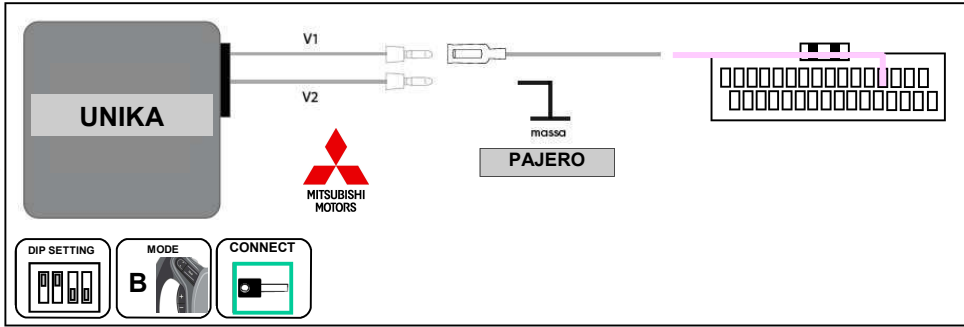

CANBUS CONNECTIONS
 (SEEN FROM CABLE OUPUT OF CONNECTORS) UNIKA rev 2.2.08

91

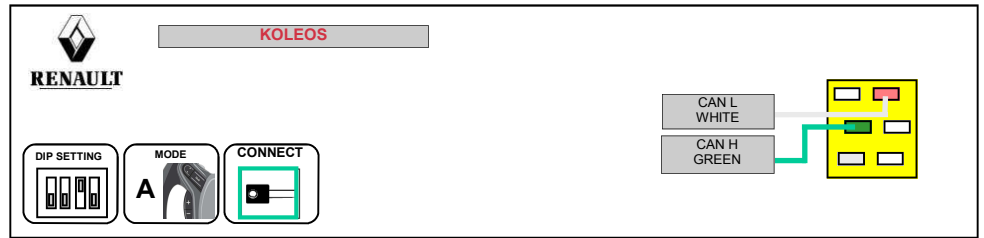

13

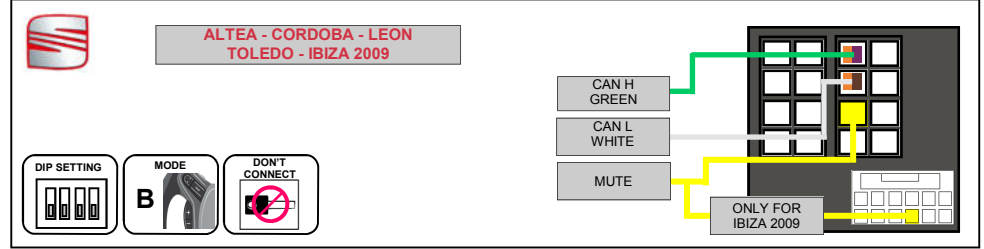

16

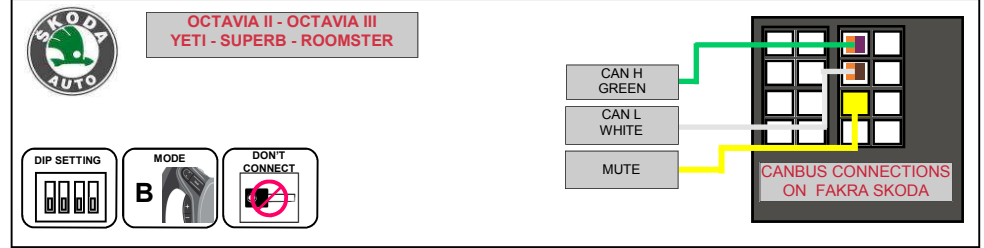

14

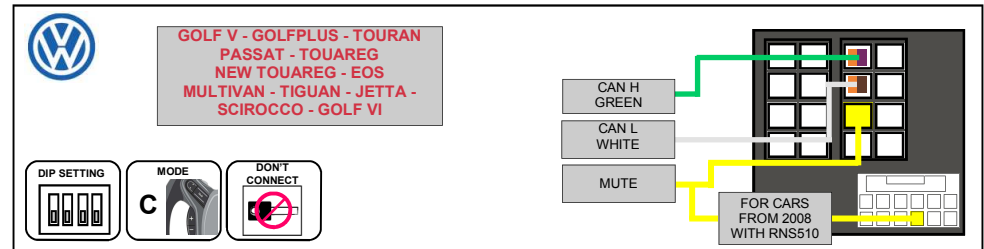

12

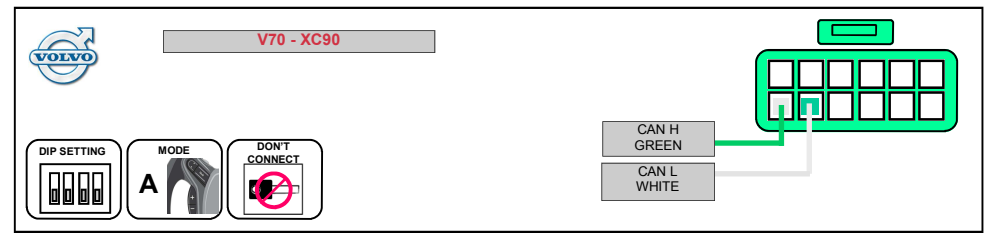

RESISTIVE CONNECTIONS with OEM radio present
 (SEEN FROM CABLE OUPUT OF CONNECTORS) UNIKA rev 2.2.08

19

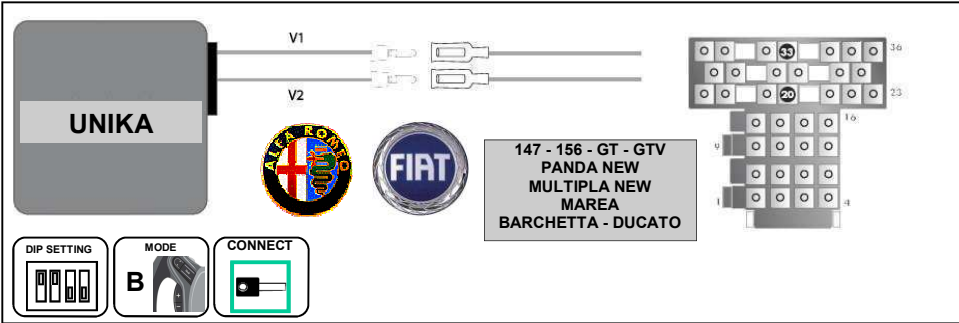

32

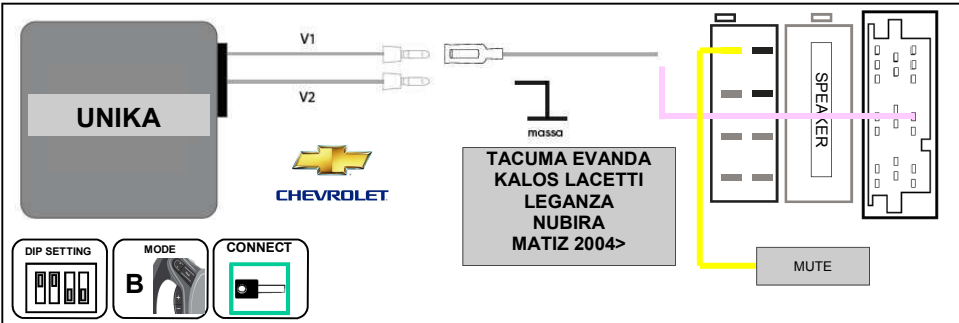

33

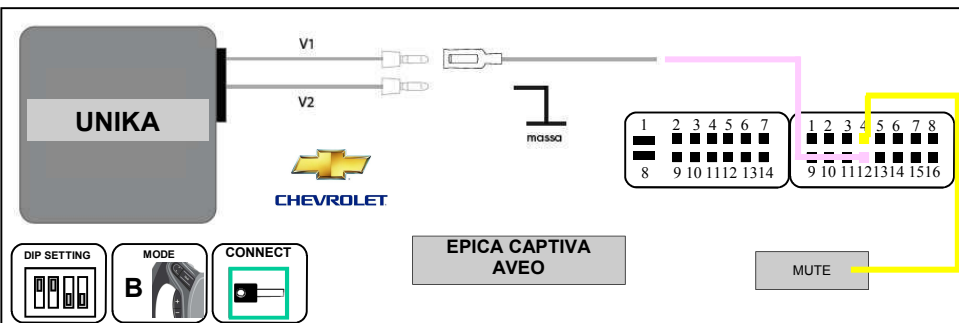

35

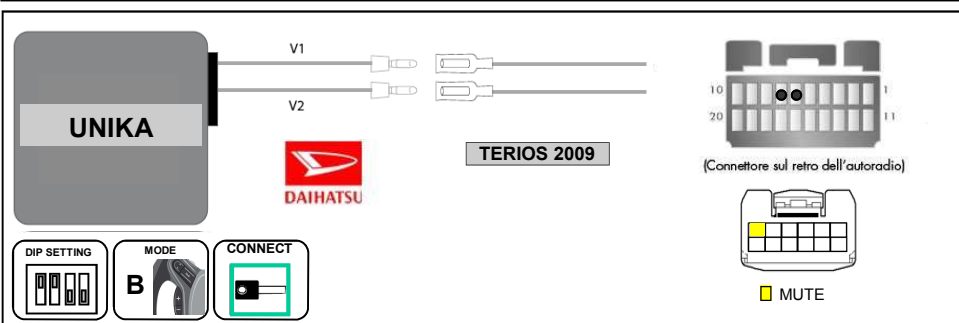

RESISTIVE CONNECTIONS with OEM radio present
 (SEEN FROM CABLE OUPUT OF CONNECTORS) UNIKA rev 2.2.08

24

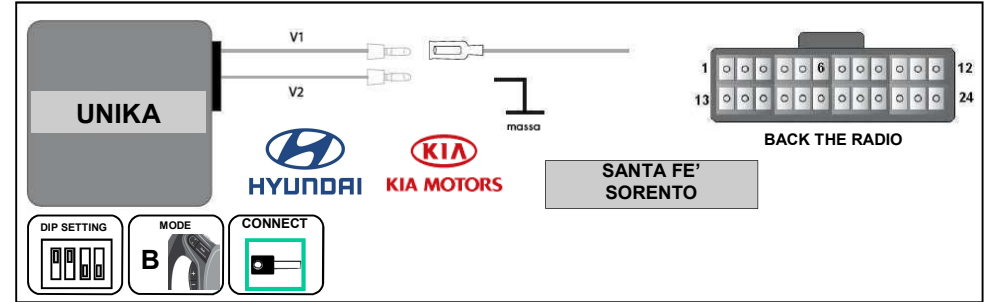

95

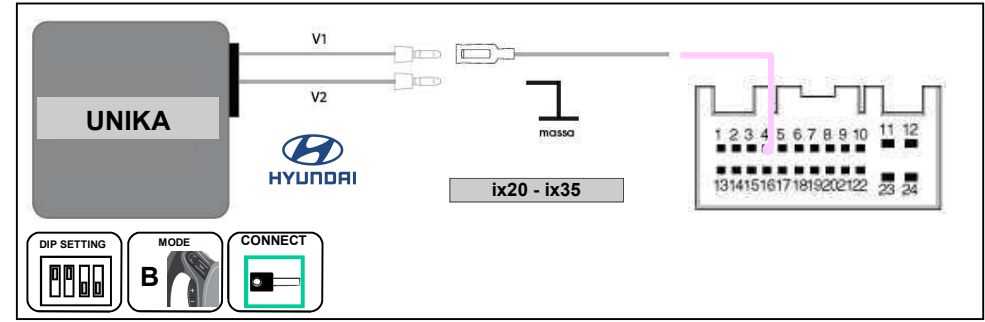

25

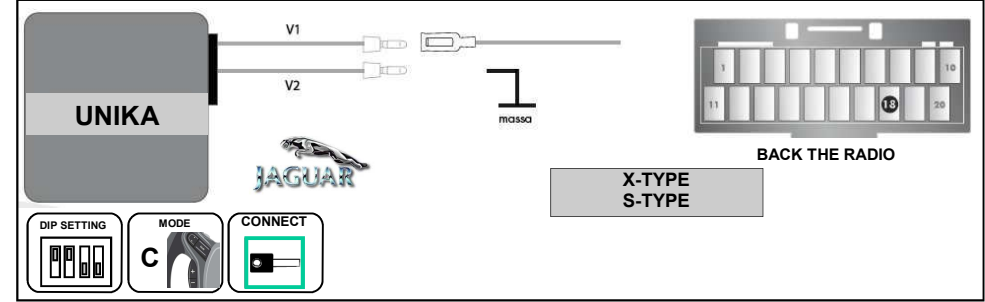

49

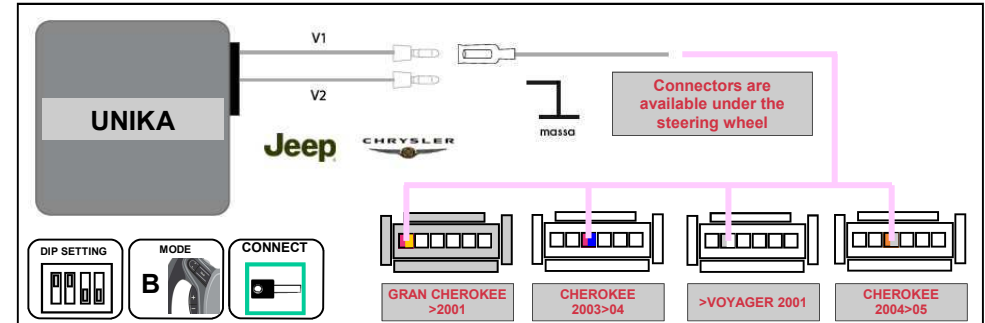

RESISTIVE CONNECTIONS with OEM radio present
 (SEEN FROM CABLE OUPUT OF CONNECTORS) UNIKA rev 2.2.08

94

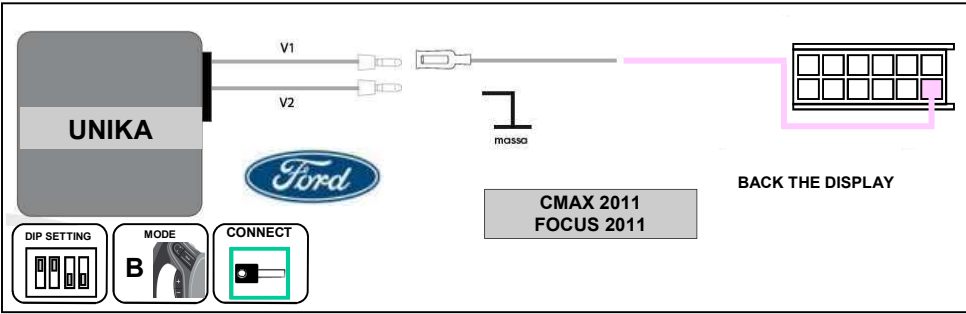

23

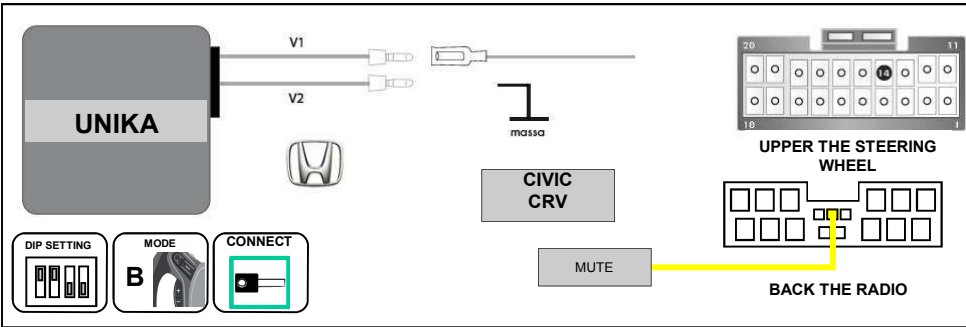

46

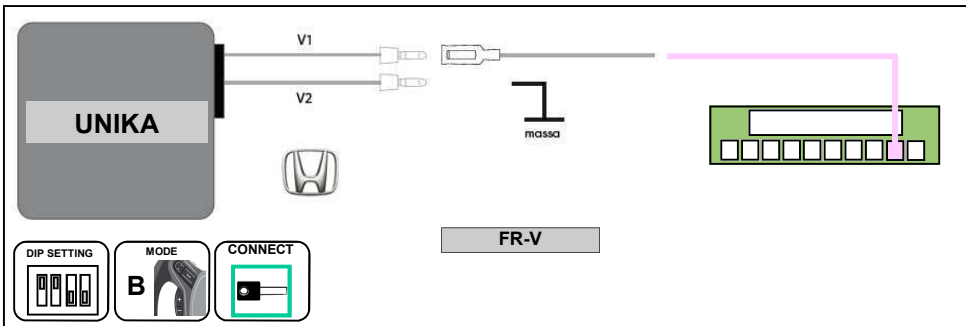

85

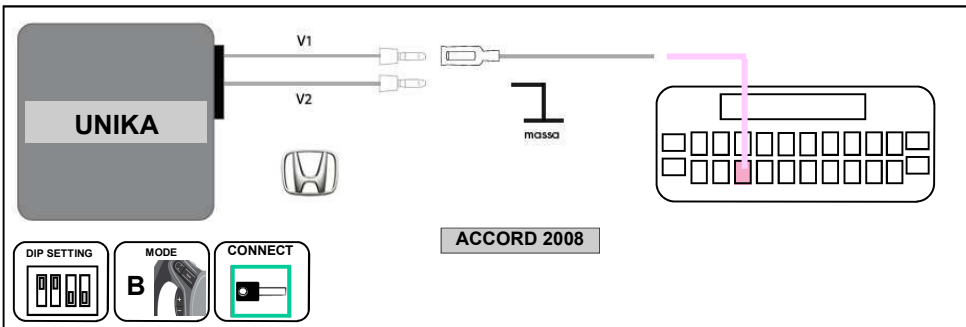

RESISTIVE CONNECTIONS with OEM radio present
 (SEEN FROM CABLE OUPUT OF CONNECTORS) UNIKA rev 2.2.08

20

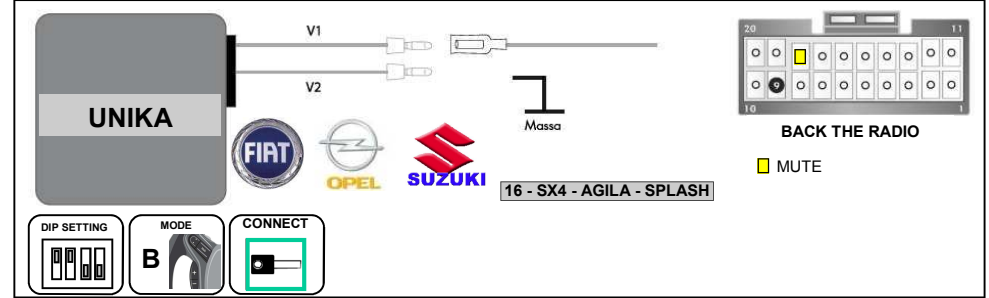

21

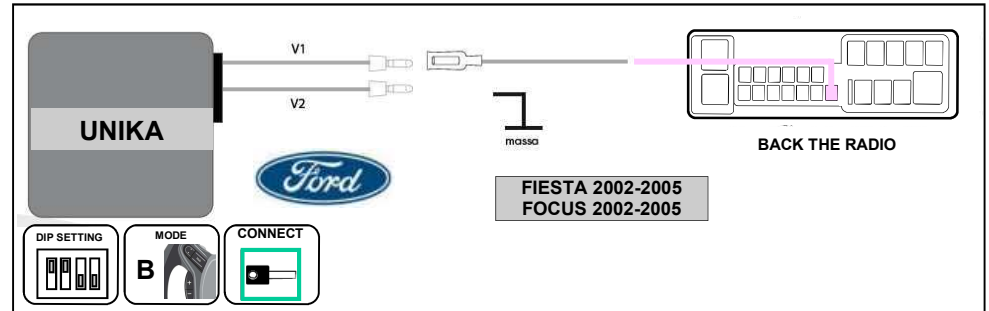

22

